

NO	DESCRIPTION	MATERIAL	Q'TY	SIZE	REMARKS
1	MOTOR	T.E.F.C	1 SET	1HPx6P	3#220/380/440V/60Hz
2	FAN	AL+ALLOY	1 SET	Ø800	4 BLADES
3	SPRINKLER HEAD	P.V.C	1 SET	80A	
4	SPRINKLER PIPE	P.V.C	4 EA	40A	
5	FILLER	P.P	1 LOT	0.4 <sup>t</sup>	ROLL TYPE
6	CASING	F.R.P	1 SET		
7	LOUVER	F.R.P	1 SET		

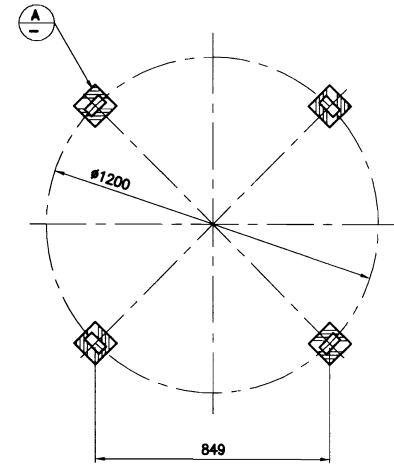
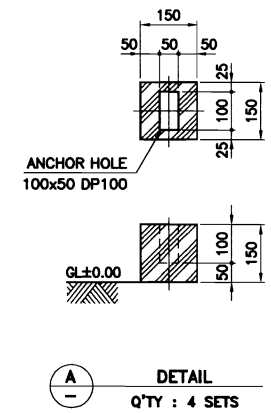

FOUNDATION

NOTE

1. REDUCER : DIRECT DRIVE TYPE
2. FOUNDATION : R.F CONCRETE (OUT OF SCOPE)
3. F.R.P TOLERANCE IS ±20mm.
4. NET WEIGHT : 280 KG
5. OPERATE WEIGHT : 490 KG

NO.	REVISION	DATE	DRAWN	CHK'D	APP'R	REFERENCE DRAWING
△						
△						
△						
△						

			<b>PROJECT :</b> COOLING WATER SYSTEM	
<b>Project NO.</b>			<b>TITLE :</b> ROUND TYPE COOLING TOWER 40 R/T ASSY DWG.	
Scale	N/S	Drawn		
Unit	mm	Design		
Date	2003.	Checked		
Size	A4	Approved		
<b>REF. NO.</b> RN373227FV00401-001			<b>Rev. No.</b> 	