

NO	DESCRIPTION	MATERIAL	Q'TY	SIZE	REMARKS
1	MOTOR	T.E.F.C	1 SET	1/2HPx6P	3#220/380/440V/60Hz
2	FAN	AL+ALLOY	1 SET	#600	4 BLADES
3	SPRINKLER HEAD	P.V.C	1 SET	50A	
4	SPRINKLER PIPE	P.V.C	4 EA	25A	
5	FILLER	P.P	1 LOT	0.4 ^t	ROLL TYPE
6	CASING	F.R.P	1 SET		
7	LOUVER	F.R.P	1 SET		

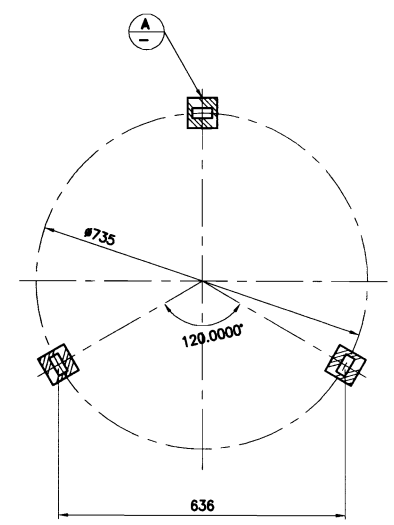
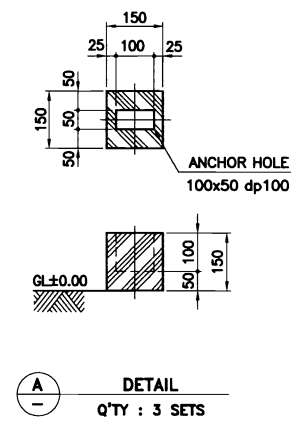

FOUNDATION

NOTE

1. REDUCER : DIRECT DRIVE TYPE
2. FOUNDATION : R.F CONCRETE (OUT OF SCOPE)
3. F.R.P TOLETANCE IS ±20mm.
4. NET WEIGHT : 105 KG
5. OPERATE WEIGHT : 215 KG

NO.	REVISION	DATE	DRAWN	CHK'D	APP'R	REFERENCE DRAWING
△						
△						
△						
△						

D H Tech Co., Ltd.
 디에이치테크(주)

Project NO. _____
 Scale N/S
 Unit mm
 Date 2003. . . .
 Size A4

Drawn _____
 Design _____
 Checked _____
 Approved _____

PROJECT : COOLING WATER SYSTEM

TITLE : ROUND TYPE COOLING TOWER
 15 R/T ASSY DWG.

REF. NO. RN373227FVP00151-001

Rev. No.